



AUTOMATIC FEEDERS

STEFF 2044

Professional power-feeding unit with fixed speeds

Safety device for a safe and effective workpiece feeding on different types of traditional **wood-working machines**.

- Improves the safety: the operator does not have to put his hands close to the tool
- Improves the finish quality, thanks to the constant and even feed-rate
- Feed-rate can be easily selected to meet every specific working need
- Easily adjustable to suit different sizes of work piece

More than 400.000 machines manufactured, over sixty years' experience. Maggi is the only European manufacturer of power-feeding units, which are 100% Italian-made, and abiding by the highest quality standards, as a result of the "Lean" manufacturing process, also known as "Toyota System".

MODEL TECHNICAL FEATURES

Main features: N.4 fixed speeds (4-8-11-22 mt/min)

N.4 wheels (diam./ thickness 120x60 mm)

Motor power: 1 HP / 0,75 kW - 1.400/2.800 RPM

Cast aluminium housing, finished on high-precision machining centers

Steel-made gear cover

Eco-friendly, rust-resistant powder coating

Manufactured according to EC standards

STANDARD EQUIPMENT

Cast aluminium housing and steel-made gear cover

1 HP motor with 3mt cable

50-Shore "Feeder Grip" rubber wheels

Package: recyclable cardboard box

MORE INFORMATION



FAST TILTING

Thanks to the **new EASY STAND** (optional) **You can tilt Your power-feeding unit in just one click** : turn the handle to unlock, tilt the feeder, turn the handle again to lock

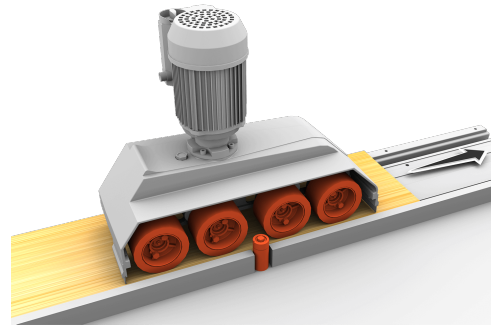

HIGH-QUALITY END PRODUCTS

4-wheel model: the ideal solution for the feeding of wooden rods and medium and/or large-size workpieces. Thanks to the two infeed-wheels and the two outfeed ones, the workpiece is constantly and evenly fed through the working process, thus remarkably improving the quality of the end products.

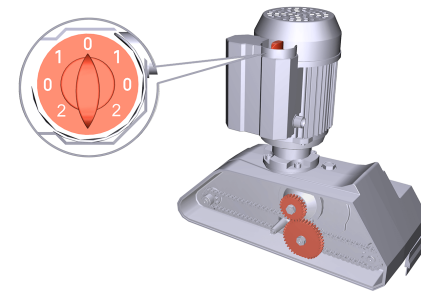

QUICK SET-UP

The speed selector allows a quick set-up of the 1st and the 2nd feed-rate and the quick change of the feeding direction back and forth; while swapping the internal gears You obtain the 4 speeds.

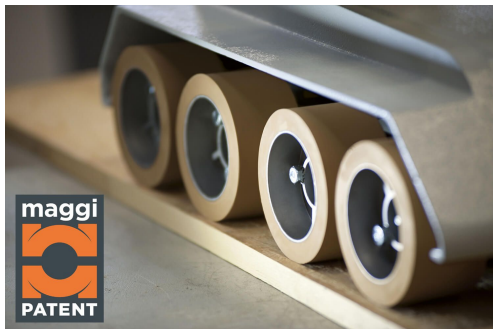

PERFECT GRIP

50-Shore wheels made of patented "Feeder Grip" rubber, provide the longest durability and the highest grip on the workingpiece. 4 wheels ensure even more grip on the panels, although the feeding process.



SAFETY AS A CORE VALUE

A power-feeder improves the safety as it feeds the workpiece close to the tool, while operator's hands are kept at a distance. Its effectiveness depends on specific design and manufacturing criteria. Maggi feeders are the only ones designed and manufactured in Italy and abiding by all EU safety norms.

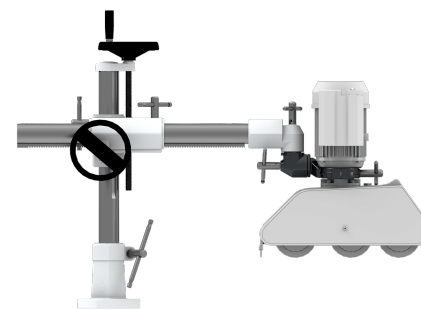

UNIVERSAL STAND

For easy positioning and adjusting of the feeding unit on the machine tool. It is easy to fix, stable and strong: foot, cross-shaped piece, pipe, joint and collar are made of cast-iron and the two columns are made of rectified steel of considerable thickness. Handles made of steel and adjusting wheels allow a quick and accurate positioning.

MORE INFORMATION



HIGH ADAPTABILITY

The 20 mm wheel suspension, with calibrated springs, allows the constant and even feeding of workpieces with different thicknesses without any additional set-up.

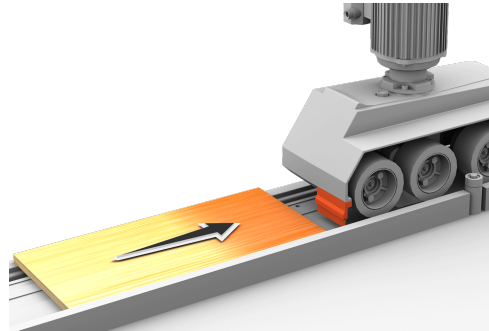

SAFETY BRUSHES

Additional safety devices, both sides of the feeding unit.



SAFE STAND

Equipped with safety restraint devices (SPS - System) preventing accidental unloads, to abide by EC safety norms.

DATA SHEET

N. of speeds back and forth	4
Fixed speeds	4 - 8 - 11 - 22 mt/min
N. of wheels	4
Wheel diameter and thickness	120 x 60 mm
Motor	1 HP / 0,75 KW RPM 1400 / 2800
Wheel suspension	20 mm
Distance between wheels	133 mm - 143 mm - 145 mm
Distance between first and last wheel	421 mm
Overall dimensions and net weight of the feeding unit	615 x 220 x 490 mm - 34 Kg
Overall dimensions and net weight of the stand	540 x 910 mm - 35 Kg
Package dimensions and gross weight (feeding unit)	670 x 570 x 330 mm - 36 Kg
Package dimensions and gross weight (stand)	800 x 330 x 330 mm - 37 Kg

